

# Smart-UPS® VT ISX Receiving and Unpacking Guide

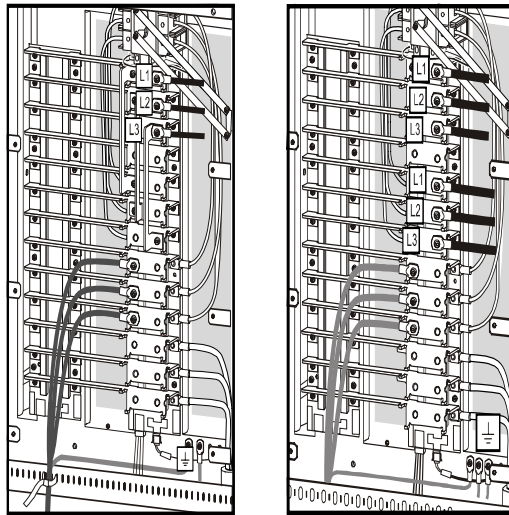

## 1 Important Safety Instructions

### SAVE THESE INSTRUCTIONS

This guide contains important instructions that should be followed when handling the UPS.

#### Symbol introduction



Note

Indicates important information.



Indicates a heavy load that should not be lifted without assistance.



See also

Indicates that more information is available on this subject in a different section of this manual.

## 2 Dimensions and Weights



See also

Safety Instructions are described in the General Safety sheet shipped with the UPS (in the documentation storage shelf behind the front cover).



Note

The UPS has castors making it easy to move to the installation site. If the UPS needs to be moved over a long distance, we recommend that you use a pallet jack to move the UPS (while it is still on the pallet).

### Dimensions

| UPS dimensions | in   | mm   |
|----------------|------|------|
| Height         | 78.4 | 1992 |
| Depth          | 43.1 | 1095 |
| Width          | 23.6 | 600  |

### Shipping weights

| UPS SKU No.  | Range     | lbs  | kg  |
|--------------|-----------|------|-----|
| SUVTRF30KH   | 400 V     | 738  | 335 |
| SUVTRF40KH   | 400 V     | 738  | 335 |
| SUVTRF30KB5H | 400 V     | 738  | 335 |
| SUVTRF40KB5F | 400 V     | 738  | 335 |
| SUVTRF20KB5F | 208 V     | 844  | 383 |
| SUVTRF30KB5F | 208 V     | 844  | 383 |
| SUVTRF20KB5F | 208/208 V | 1289 | 585 |
| SUVTRF30KB5F | 208/208 V | 1289 | 585 |
| SUVTRF20KB5G | 480/208 V | 1289 | 585 |
| SUVTRF20KB5G | 480/208 V | 1289 | 585 |
| SUVTRJ20KB5F | 200/208 V | 1327 | 602 |
| SUVTRJ30KB5F | 200/208 V | 1327 | 602 |

### Battery Module (consisting of 4 Battery Units). Shipping separately

|              |           |
|--------------|-----------|
| 4 x 52.8 lbs | 4 x 24 kg |
|--------------|-----------|

## 3 Inspection

### External inspection

While the shipment is still on the pallet, inspect the shipping material for any signs of damage or mishandling. Do not attempt to install the system if damage is apparent. If any damage is noted, file a damage claim with the shipping agency within 24 hours, and contact APC Technical Support to inform of the damage claim and the condition of the shipment.

Compare the components of the shipment with the bill of lading. Report any missing items to the carrier and to APC Customer Support immediately.

Verify that labelled shipments match the order confirmation.

## 4 Move to Installation Site

With the system on the pallet, use a pallet jack to move to the installation site.

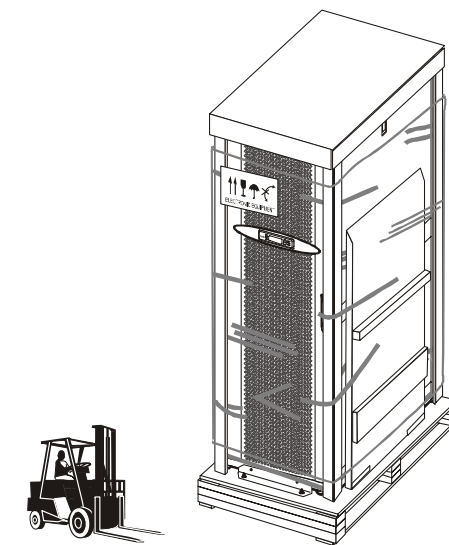

## 5 Removal of Packaging



Note

If the system has to go into storage prior to installation, do not remove the packaging now. APC recommends to store the system in an indoor, temperature-controlled area, free of conductive contaminants until the time of the installation.

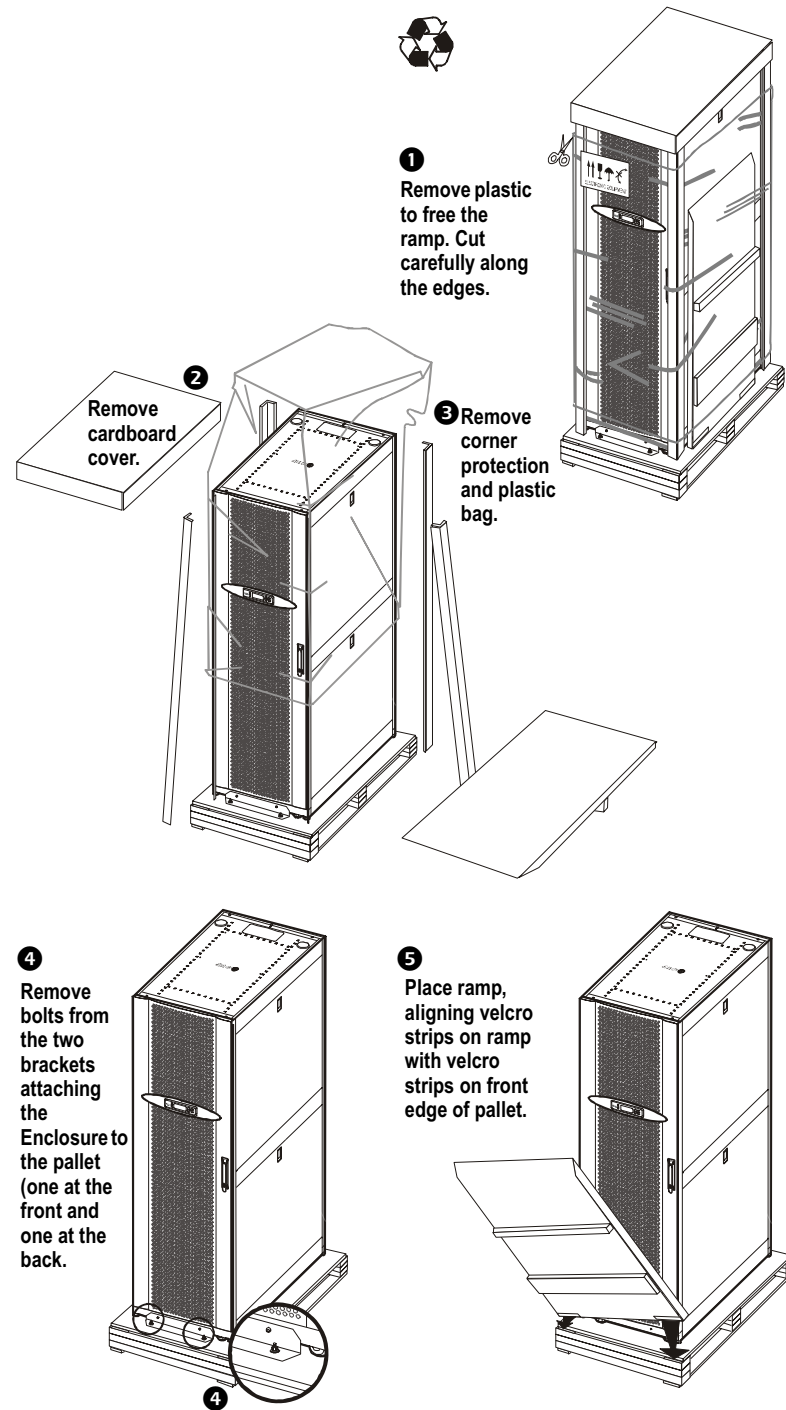

Two people to roll Enclosure from pallet.

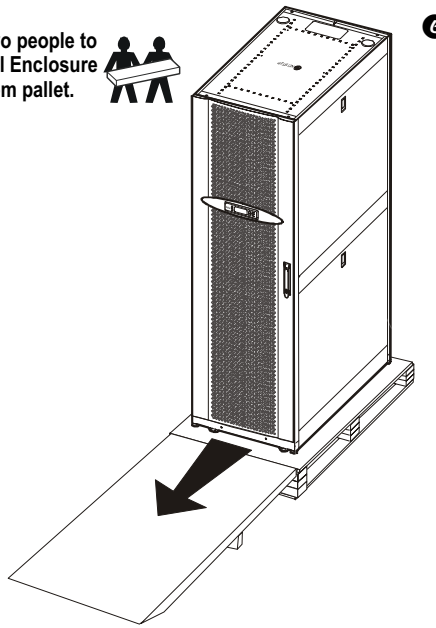

## 6 Documentation Storage

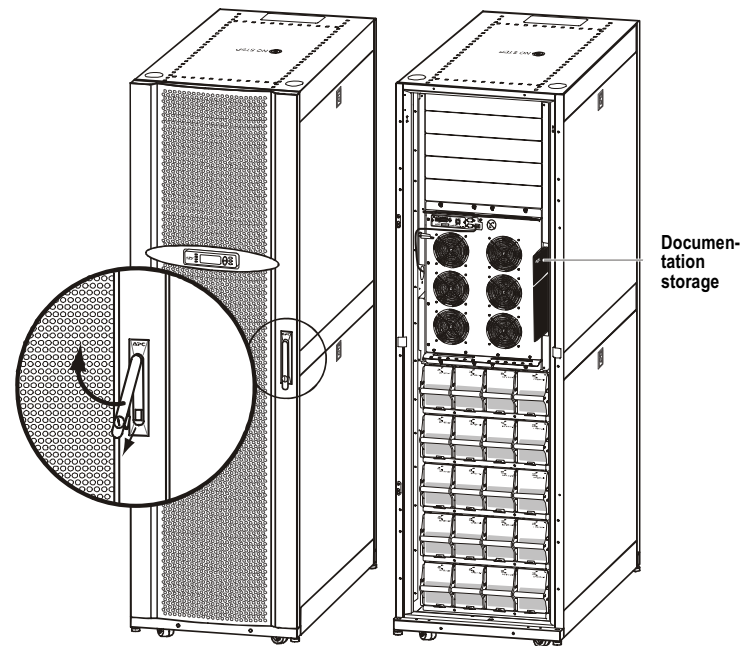

## 7 Contact Information

If a problem occurs, phone (1)(800)800-1272 (toll-free) for U.S./Canada, or contact our Ireland office at +353 91 70 2000 (Europe, Middle East, Africa) or go to Web Support: [support@apc.com](mailto:support@apc.com). For country-specific centers: go to [www.apc.com/support/contact](http://www.apc.com/support/contact).